



Dear Customer,

We would like to provide you with the following important information.

It is strictly forbidden to start or operate a ROTAX MAX engine without the clutch drum mounted! The available instructions have to be followed at all times!

▲ WARNING

Starting a ROTAX MAX engine without the clutch drum mounted, or non proper mounted, will result in an excessive mechanical damage of the engine and can also lead to serious injuries or death of mechanics, pilot's and/or 3rd parties.

■ ATTENTION

For proper mounting of the clutch drum with sprocket to the crankshaft:

- ⇒ block the starter gear with the fixation tool (ROTAX part no. 676 205)
- ⇒ degrease the thread of the crankshaft and the hex nut (12).
- ⇒ apply LOCTITE 243 (B) to the thread of the hex nut (12).
- ⇒ fit the hex nut (12) to the crankshaft and tighten the hex nut with 35 Nm.
- ⇒ remove excessive LOCTITE from the crankshaft.
- ⇒ remove fixation tool for the starter gear.

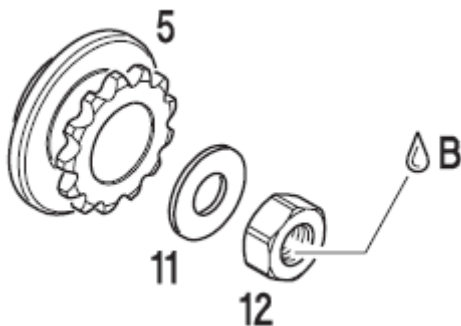

Thank you for your attention.